

VTC ULTRASONIC SEAL SAFE TECHNOLOGY FOR VALVE PACKERS



“VTC-VIP 3.1 Ultra” is a stationary valve type bag filling machine for packing easy-flowing powdery bulk materials into valve bags with a simultaneous weighing and automatic bag sealing of the bulk material from 20 to 50 Kg.

Feed Rate: 120-180
Bags/Hr

Bag Type: Valve Type

Packing Range: 20 to 50 Kg

Accuracy in 50 Kg Bag: $\pm 100g$

KEY FEATURES

- Clean and dust free operation
- Latest technology for bag sealing filling and sealing with user-friendly design.
- Two stages of filling of the material inside the bag ensure better accuracy in weighments
- Inflatable Sleeve is introduced for bag gripping on the filling spout which also helps in preventing back pressure
- Uses pre-stitched valve-type bags, eliminating the need for post-filling stitching, and is compatible for packing powder in in PP, HDPE (woven), or paper bags (laminated)
- Easy availability of spares and after-sales service

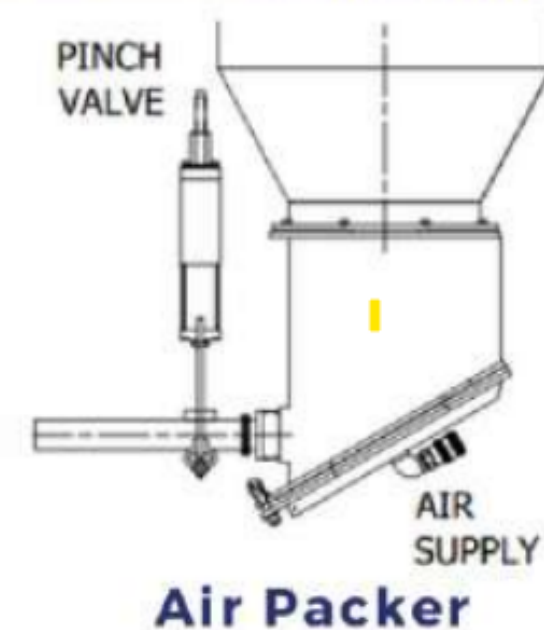
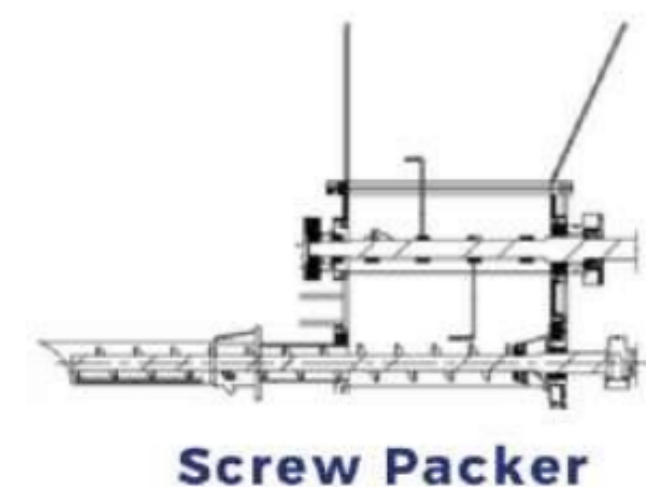
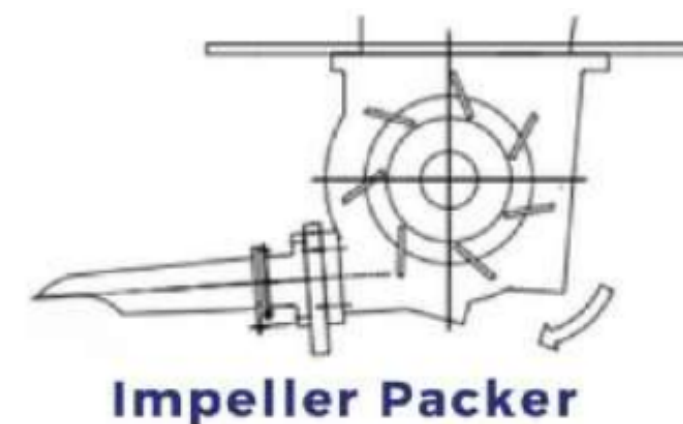

Our **Ultrasonic feature**, compatible with any **valve bag**, mounts effortlessly with our innovative **feeders** for **exceptional efficiency**

VTC ULTRASONIC SEAL SAFE TECHNOLOGY FOR VALVE PACKERS



MACHINE SPECIFICATIONS

Model	VIP 3.1 Ultra	VIP 3.2 Ultra
No. Of Spouts	1	2
Impeller Type	Vertical	Vertical
Feed Rate (Bags/hour)	120-180	240-300
Approx. Bag Dimension for 50Kg (mm) *Dimension will change based on your bag size*	750mm × 500mm × 100mm	
Bag Type	Valve type with sleeve	
Sealing Technology	Ultrasonic (Heating and closing)	
Bag Material	HDPE, Paper, PP, etc.	
Filled Weight (Kg)	20~50	
Accuracy in 50Kg Bag	100g in all filling range	
Material Can Be Packed	Powder (Building Material & chemicals) like Cement, Fly Ash, Ready Mix, Wall Putty, Gypsum, Chemicals, Mortar etc.	
Power Supply	380 / 440 VAC 3φ @50Hz	
Air consumption for Single Spout	10 CFM @100 PSI Per Spout	
Approx. Machine Dimension of Single Spout (LWH)	750 mm X 1230 mm X 2500 mm	
After Sales Service & Spare Part Availability	Yes	



APPLICATIONS

- Cement
- Fly Ash
- Gypsum
- Lime
- Ready Mix
- Chemicals
- Dry Wall Putty

TYPE OF BAGS



VT CORP PVT LTD

Address: 901, Windfall, Sahar Plaza, J B Nagar, Andheri (East), Mumbai – 400059, India
Tel: +91 22 6108 1200 | Mob: +91 9323125586 | Email: sales@vtcorp.in | www.vtcorpindia.com

ISO 9001-2015 CERTIFIED COMPANY

@vtcorpindia    